

Vortex Separation Technologies

Engineered
Solutions to
Separation
Problems

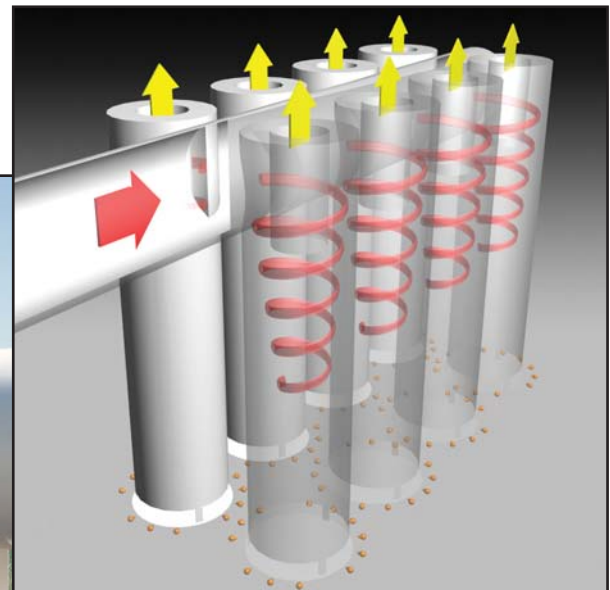
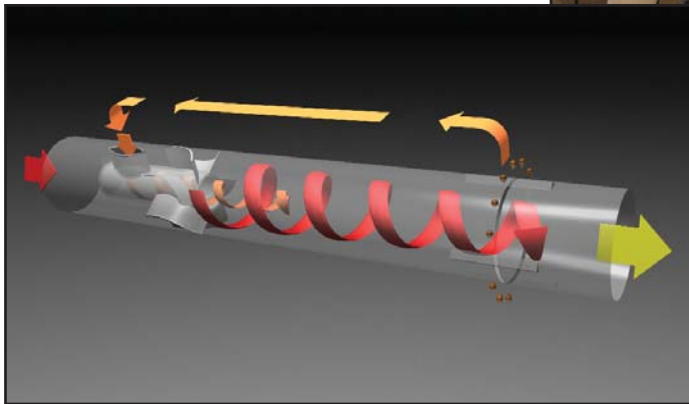

T F **TAYLOR FORGE**
Engineered Systems

Vortex Technology **The VORTEX CLUSTER**

Internals use the high-energy momentum of fluids to produce a high “G” force which sends the liquids and solids against the Vortex Tube wall and creates a sufficient ΔP between liquid and gas to provide superior separation.

Separation of Gas/Oil/Water mixtures is traditionally accomplished by gravitational settling. Long separation periods of the liquids are the result of close densities and limited separation force. In many cases, the qualities of the separated components may not be as good as desired due to the characteristics of the oily fluid. In recent years Vortex Technology has become an effective and economical alternative.

Vortex Technology is available in two configurations:
Vortex Clusters or
Vortex Tubes.



The VORTEX CLUSTER

The “Vortex Cluster” is suited for gas dominant, liquid dominant, or liquid/liquid separation. Lower retention times and dramatically improved separation are the result of fluid control. This results in a smaller new vessel, improved separation, and increased flow through existing vessel with a Retrofit. No foam, up to 90% turndown.

2-phase separation (gas/liquid) is the result of increased angular velocity, which creates a ΔP between liquid and gas. At optimum conditions a liquid entrainment efficiency of 99.9 % removal of solids and liquid particle. This is further enhanced with reduced gas under carry. No Foam, No Additives.

3-phase separation (gas/liquid/liquid) will dramatically improve liquid/liquid separation. The controlled angular velocity promotes coalescence of smaller droplets to larger droplets when the inertial force on a droplet is greater than surface tension of a similar droplet. Because of a difference in density, the coalescence is achieved when the higher density droplet goes to the wall. The larger droplets created will then separate when in the quiescent zone of the vessel. Residence time is dramatically reduced. It should be noted that liquid/liquid separation is dependent upon operating oil viscosity.

The VORTEX TUBE

The “Vortex Tube” is suited for gas dominant separation. Curved vanes of the ‘Fixed Vane Assembly’ use the high-energy momentum of fluids to produce a high “G” force which sends the liquids/solids against the Vortex Tube wall and creates a sufficient ΔP between liquid and gas to provide superior gas/liquid separation.

The curved vanes of the ‘Fixed Vane Assembly’, or as is commonly known as ‘Whirlyjig’, spin the inlet stream upon entry into the vortex tube. The resulting cyclonic action forces the free liquids and solids to the wall of the tube and flowing to the circumferential gap. The liquids and solids are sucked through the gap, together with a portion of the gas stream, into the annulus between the vortex tube and the body shell. The low-pressure core of the vortex creates suction at the gap. This suction or Recycle is achieved by means of a single port from the ‘Fixed Vane Assembly’ into the annulus. The liquids/solids, having passed through the gap, drop out due to gravity and drain to the sump. The Vortex Tube then has the gas re-enter through the Recycle Port and merge once again with the main stream. The result is thoroughly scrubbed and liquid free gas exiting the scrubber.

Vortex Tubes may be Horizontal or Vertical in design. They may also be designed to handle surges of liquid/solids in our Vertical or Horizontal Knock-outs.

The liquid sump/boot may be vertical (typical on single tube horizontal separators and non surge horizontal separators) or, when designed for surges, a horizontal sump/ boot may be used. The sump/boot in the vertical separators is located below the Vortex Tube section.

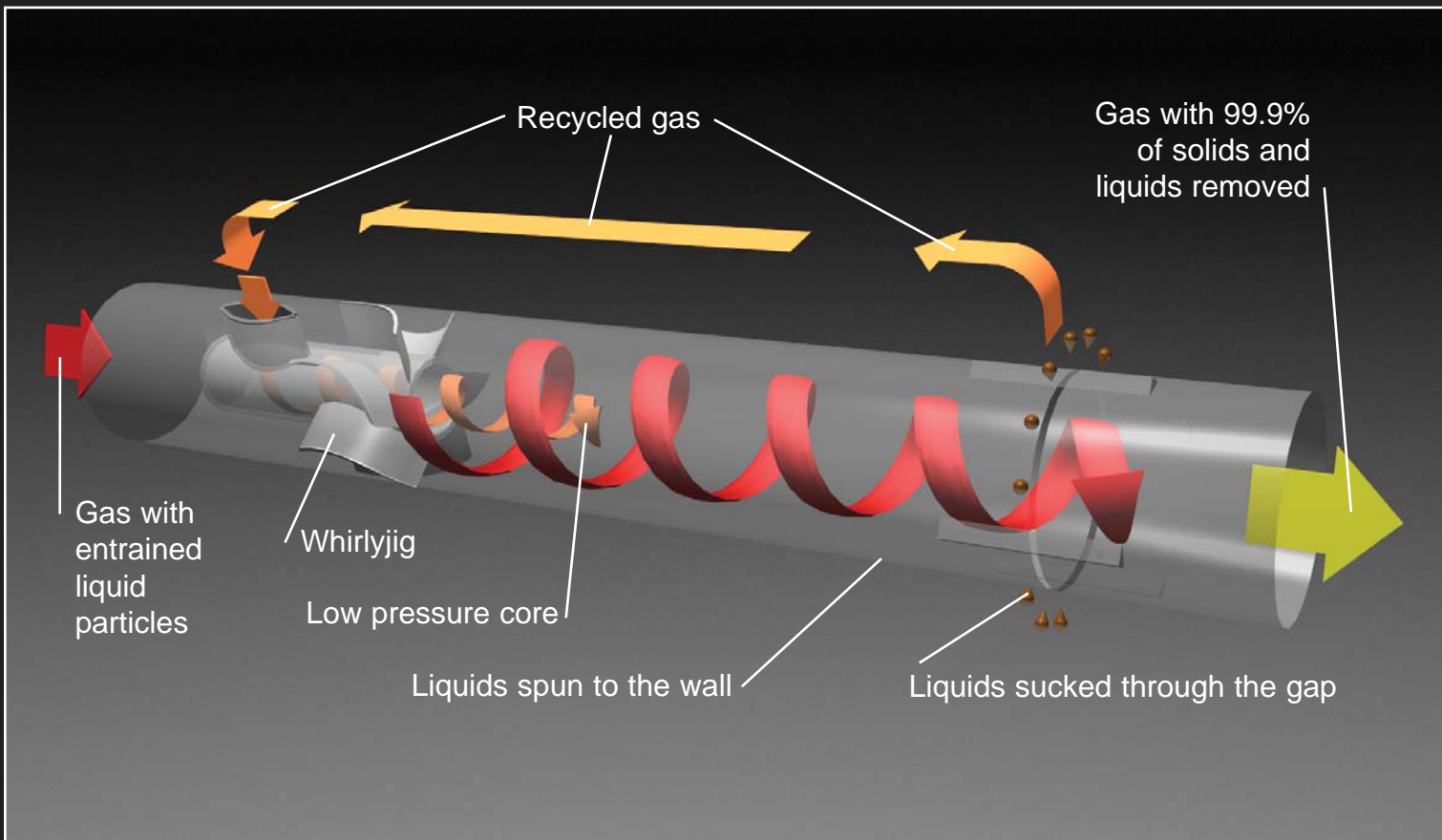
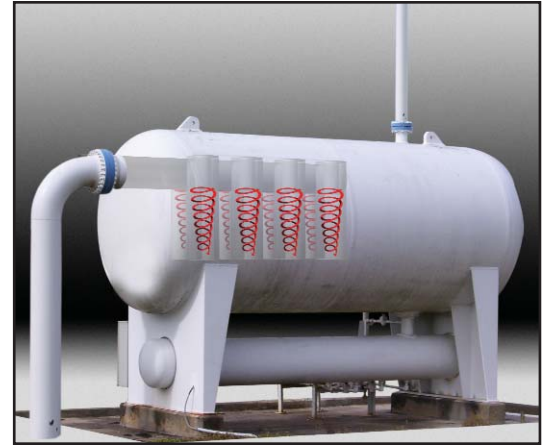
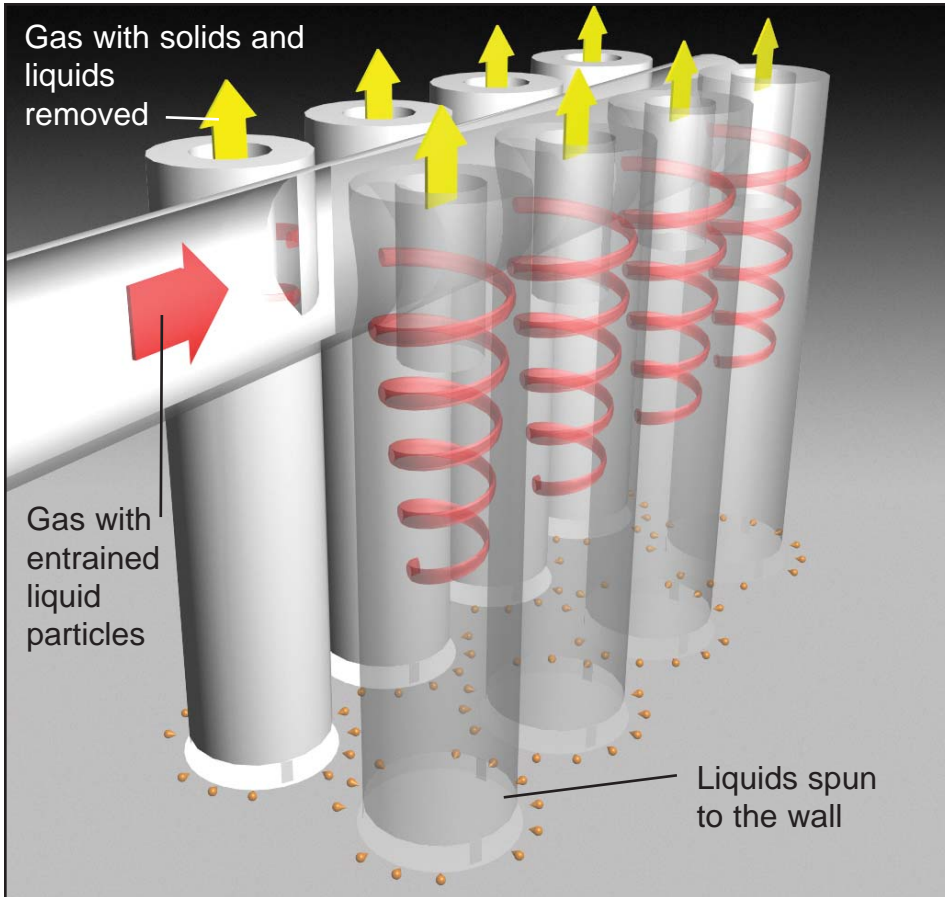



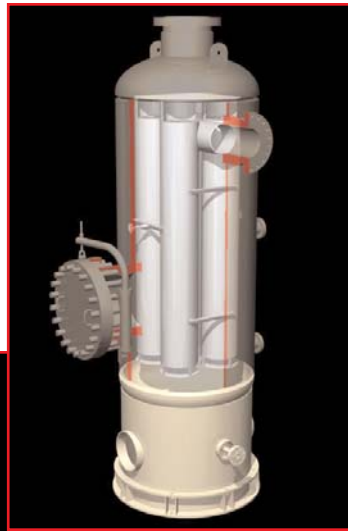

TF
TAYLOR FORGE
ENGINEERED SYSTEMS

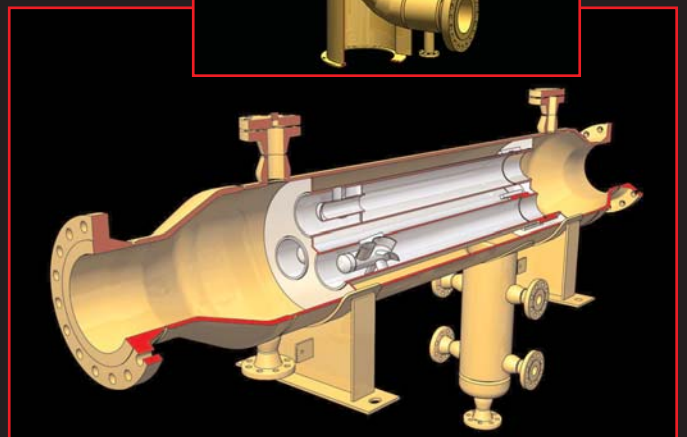
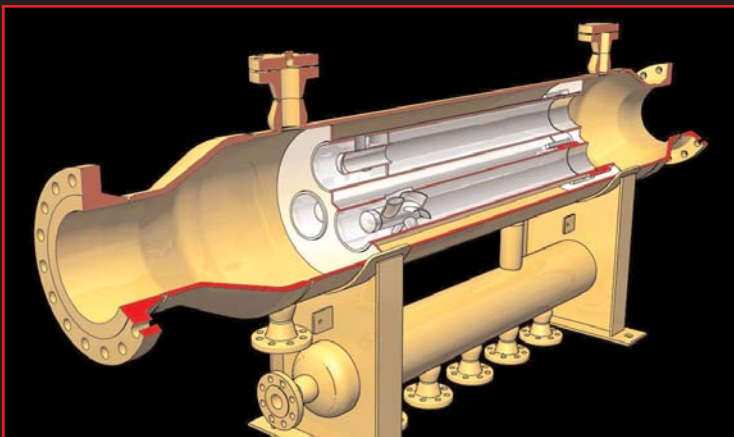
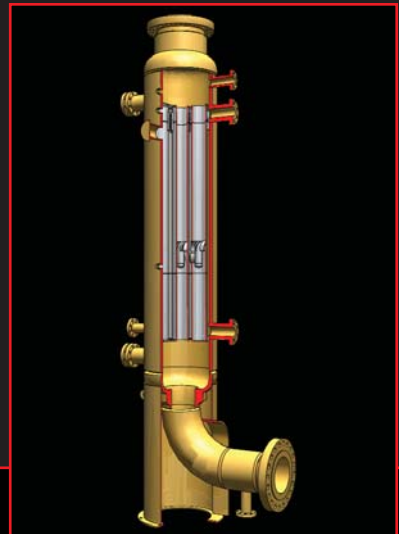
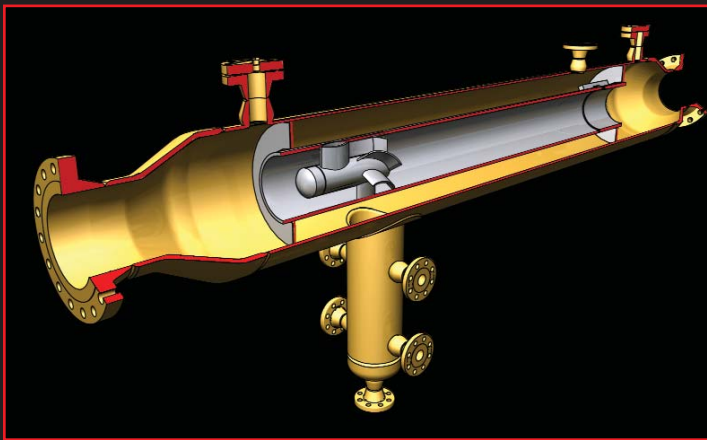
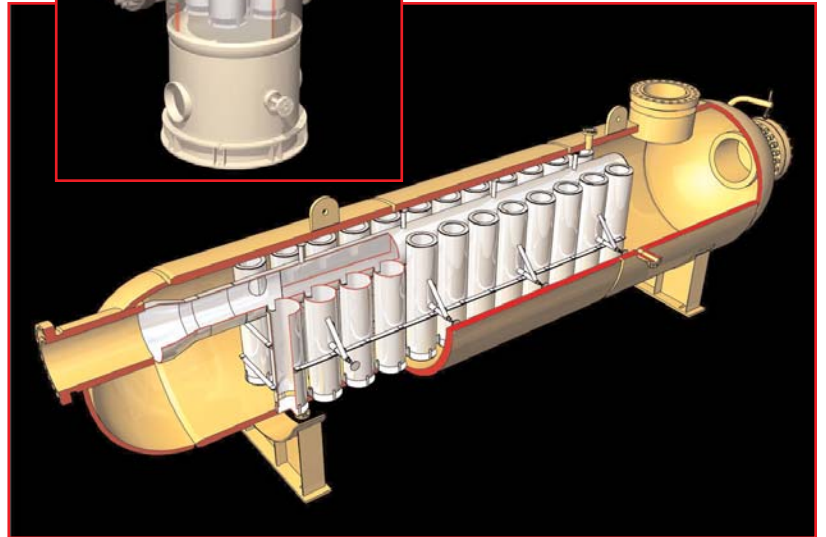

**Slug Catcher
(Modularized for Shipping)**



Slug Catchers

**Pressure Vessels
(Steam Drum)**



**NASA Pressure Vessels
(A3 Test Stand)**

**Extruded Outlets
(Air Grid Hub and Arm)**



Cooler Headers

**12,000 psi
Y-70/Y-80
Scraper
Trap Skid**



**Scraper Traps
& Trays**

**High Yield
and Nuclear
Tees and Caps**



**Vortex
Technology
Separators**

**TF TAYLOR FORGE
Engineered Systems**

www.tfes.com

Traditionally Dependable

208 N. Iron Street
Paola, Kansas 66071
Phone: (913) 294-5331
FAX: (913) 294-5337